

HP2500 Series

Residential Raised Floor System

SOLITILE[®]
for metropolitan apartment buildings

improve quality of living

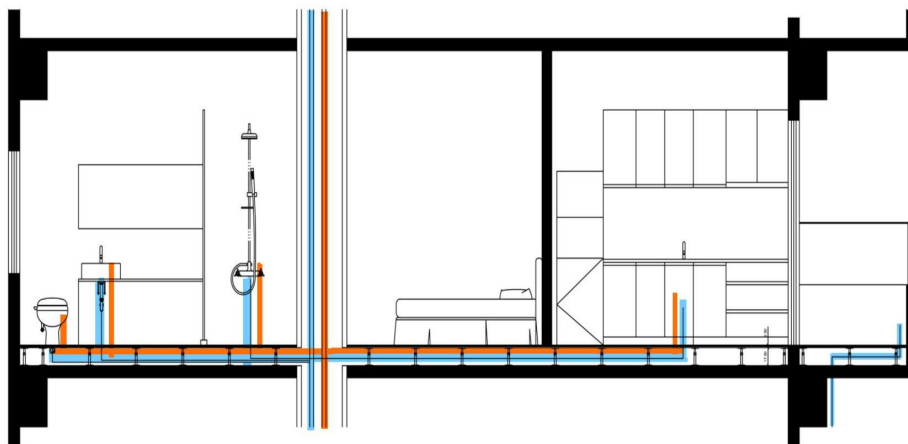

noise reduction
&
life-time least maintenance costs



SOLITILE® HP-2500

I. The System

Solitile HP2500 raised floor system is designed and developed specially for top-finished by stoneware tiles, particularly ideal for metropolitan residential apartment buildings. The unique access panels are good to be directly installed and top-finished by stoneware tile such as granite, marble, and porcelain tiles. The patented access panel structure is a state-of-the-art design, which is composed of concrete surface, and firmly supported by special inner-lock galvanized steel sheet at bottom and core of the panels

HP2500 system consists of special design monolithic access panel, full steel pedestal, bolted stringer understructure, and corner lock fixing cap.



1. access panel

Access panels are made of monolithic artificial stone core, bare finish, which is supported and firmly inner-locked by special design galvanized steel sheet at bottom and inside, recess 5 mm 1/4 circle at 4 angles for corner lock. 25 mm thick (HP2511) for residential indoor, 30 mm thick (HP3011) for lobby, aisle, and public areas.

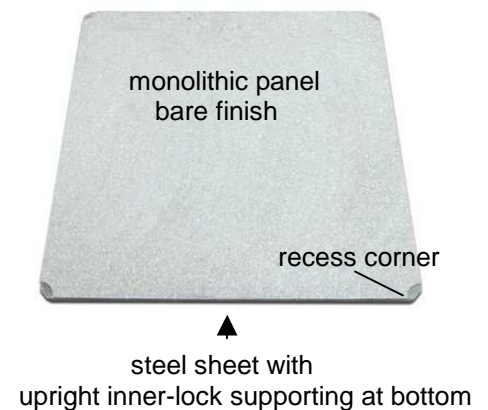

2. understructure:

pedestal: cross-shape top plate for fixing by corner lock caps from top

stringer: square tube stringer topped by plastics divider



corner-lock fixing cap: galvanized steel fixing cap fastened from top, at intersection of panel angles.



3. System height – 120 mm ~ 600 mm

clearance under access panel for utility pipes distribution: system height - 60 mm



4. top-finish: good for bonded by all type floor coverings, particularly for stoneware tiles. This is unique features of Solitile HP2500 system. In the concurrent market, almost all other access floor manufacturers are not able to provide access panel which suitable for direct stoneware tile bonding job site. Structurally all other type access floor such as steel/cementitious, wood core, or calcium sulphate access panels, are not suitable to be bonded by stoneware tiles.

stoneware tiles bonding on HP2500 –

granite, marble, porcelain tile, ..
bonded by applying thin-set adhesives,

resilient floor coverings on HP2500 –

carpet, vinyl, rubber, wood, ...
bonded per floor covering manufacturers specified/approved adhesives.

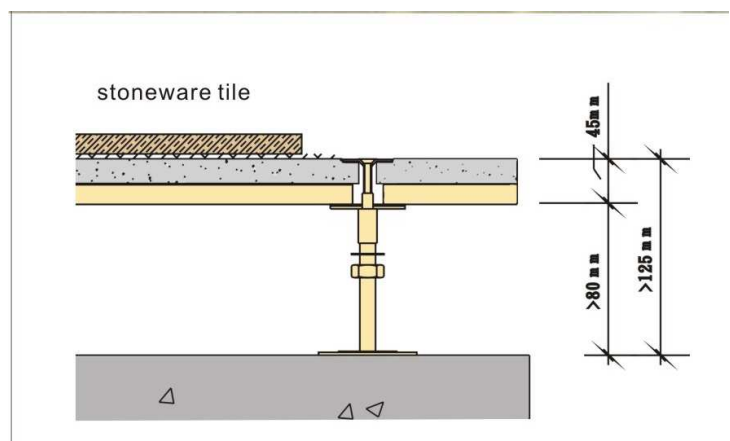

5. safety: non-combustible:

the system rated non-combustible, which features high safety standard particularly for using in metropolitan high-rise buildings

II. Improve quality of living

1. Noise Control

noise reduction: Noise usually caused by upstairs occupants when moving of chairs / tables, steel cup/plastics cup, spoon, glass ball dropping onto stoneware or wood floors. By installing HP2500 system at upstairs, such noise caused at downstairs shall be reduced averagely 50%.or more than without HP2500.

A noise reduction test conducted in a high-rise residential building, HP2500 installed on slab and top-finished by stone tile (stone tile/HP2500) vs. same stone tile installed onto floor slab (stone tile/slab) same room at upstairs.

subjects for testing: steel cup dropped from 40 CM height, each 30 times.

noise source from upstairs, sound receiving at downstairs.

A. background sound at downstairs: avg. 40 dB

B. sound received at downstairs by steel cup dropped on stone tile/slab: avg. 70 dB

C. sound received at downstairs for steel cup dropped on stone tile/HP2500: avg. 50~55 dB

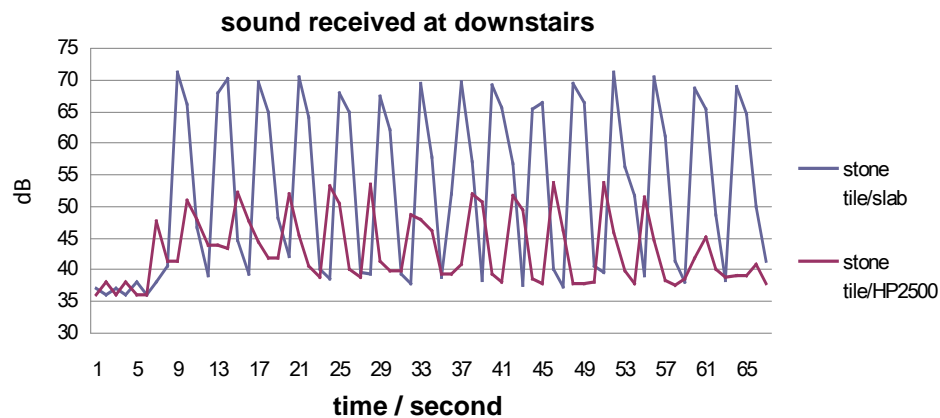

2. Flexibility and Changeability

A. SI (Skeleton Infill) Building implementation

B. efficient and quite renovation / low renovation, maintenance costs

SI (Skeleton Infill) Building concept has been introducing in Japan for more than a decade. There are more and more SI buildings in Tokyo metropolitan since beginning of 2000s.

The SI buildings consists of following fundamental approaches:

1. Changeability – walls in-between rooms are changeable
Living room, bedroom, kitchen, toilet, bathroom, can be changeable. The changeability shall meet occupants' or new occupants' requirements at different stage of occupancy.
2. Capability for easy maintenance and relocation: utility pipes and electricity wires are distributed underneath HP2500, not embed in the building structure or walls. This enables future maintenance and relocation fast, easy, low costs, and proceed under minimum noise to neighbors.
3. Reasonable deployment of all utility pipes: Utility pipes (water, sewage, toilet) from the common usage, shall be distributed only inside the occupant's premise, passing through neither upper floor nor lower floor. By mean of this, minimum interference during repairing may be occurred when there is leakage, maintenance, or re-location of the pipes.

Figures 1. below shows fundamental difference between SI and non-SI buildings
 In the SI building design, HP2500 can be installed overall floor space, both interior and public areas.

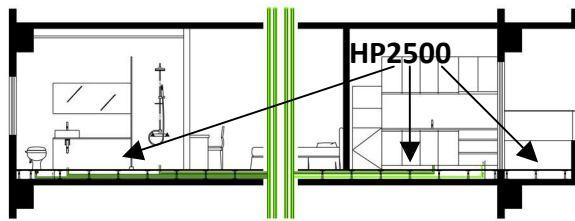

A. SI building – all utility pipes and wires are distributing in each premise underneath raised floor, not through upper floor, nor lower floor concrete slabs.



B. non SI building – conventional buildings' pipes and/wires are embedded inside structure slab or walls, some distributed at top of lower floor. Toilet flushing, leakage and future maintenance are often a tension in-between upstairs and downstairs .

Figure 1

Figure below show SI building changeability of partition wall and room-type due to different usage stage by original occupant, or move-in by new occupants who have different life style and may need other arrangement.

Example for stage of usage – room layout in esidental apartment building installed HP2500

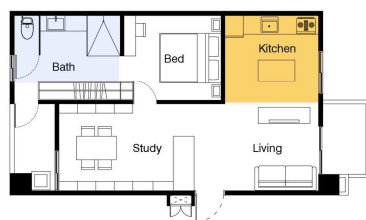

young couple moves in



children join the family after a few years or new occupants of more family members



children grown up and move out, or new occupants require new arrangement

III. Applications

1. residential apartment buildings interiors

- Per SI building concept, HP2500 is designed to install covering interiors of each premise.
- A. Walls of all rooms are preferred to install on top of HP2500 system. This enables future changeability of walls for room re-arrangement, enlarge or downsize.
 - B. Utility pipes are distributed as planned, installed underneath HP2500 access panels, no pipes are distributed in the concrete slab, or walls in-between neighbors.

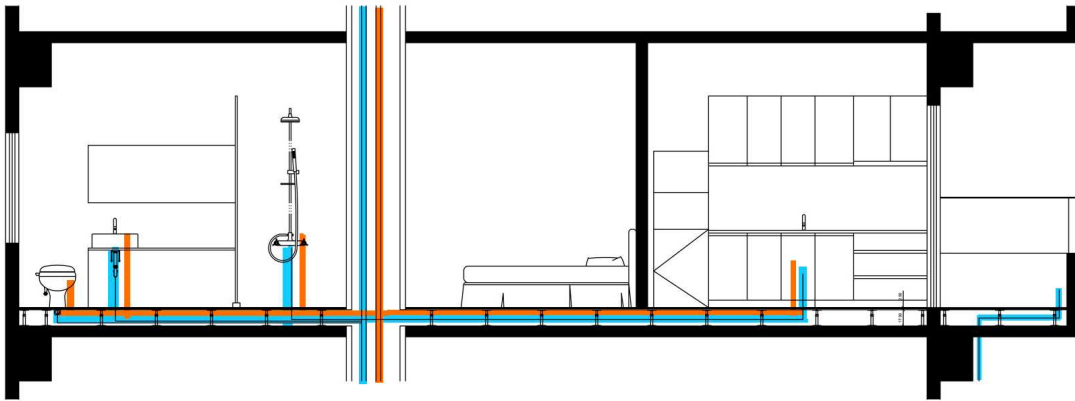

2. building lobby, aisle, public areas

HP2500 are designed to install at public areas such as lobby, aisles, to accommodate main utility pipes distribution underneath, and for extension into individual premises.



IV. Installation

AA. understructure –

Under-structure: same procedure as ordinary access floor

A-1: install pedestal and bolted stringer

A-2: level pedestal/stringer by laser alignment

A-3: apply adhesive under pedestal base plate

BB. lay in access panels

B-1 lift bare panels by assistance of 3-sucker lifter.

B-2: lay panels on grid in order, check leveling in sequence.

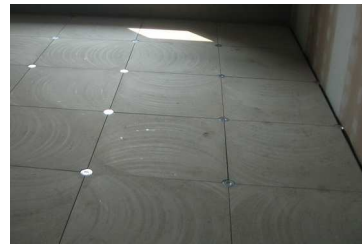

laser alignment leveling / apply adhesives after laser alignment / fasten fixing caps after apply adhesives

CC. perimeters - cut access panels for perimeters by stone tile cutter.

CC-1: In case last piece access panel against wall less than 15 cm is inevitable:

suggest cover the gaps by plywood (minimum 18 mm thick), supporting by wood studs.

CC-2: cutting edge and perimeters: avg. 2 mm allowance to wall and sealed by 5 mm foam stripes at sides of panels. .

DD. top finished by - resilient floor tiles: carpet tile, rubber tile, vinyl tile, and etc...

corner-lock (optional): access panel installed either corner-locked or loose-laid.

Bonding procedure and adhesives as per floor covering manufacturers instruction.

EE top finished by – stoneware tiles: granite, marble, porcelain tiles,..

E-1: clean and rinse panels' surface and stone tiles' back.

E-2: apply thin-set adhesive by 10 mm square notched trowel, coverage about 5~6 piece access panels each time.

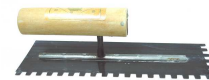

Notched trowel thin-set adhesive

E-3: apply avg. 1 mm thick thin-set adhesive at stone tiles' back

E-4: install stone tile, insert tile spacer at angles, 2 mm gap in-between tiles forms automatically, check leveling one by one in sequence.

E-5: clear thin-set residual inside the 2 mm gap in-between tiles.

E-6: grout the gaps: allow 24 hours thin-set adhesive setting time before grouting. (follow instruction by the adhesive and grout manufacturer) .



rinse panels and tiles



apply adhesive on panels



apply adhesives on tiles



insert tile spacers, form 2 mm gap for grouting, check leveling in sequence

V. Specifications – HP2500 series

System: Solitile HP2500 Access Floor System

Manufacturer: Netfloor, Inc.

Module size: 602 mm X 602 mm (normal)

Access panel actual size: 599.5 mm X 599.5 mm

System height: standard height for residential buildings 120 mm ~ 250 mm

standard height for aisle, lobby, etc: 120 mm ~ 600 mm

Access panel thickness:

25 mm thick for residential indoor

30 mm thick for lobby, aisle, and public areas.

Top-finish: suitable for all type of stoneware tiles, granite, marble, porcelain, and etc.

and suitable for all type of resilient floors, carpet, vinyl, wood, and etc.

Loading and safety performance

Concentration load: when testing by 1" square indenter, access panel shall be

25 mm thick access panel: 360 kg (800 LB) less than 1.5 mm depression.

30 mm thick access panel: 450 kg (1000 LB) less than 1.5 mm depression

loading property estimated increase 15 ~ 20% when top-finished by stoneware tiles.

Concentration ultimate load:

25 mm thick access panel: greater than 700 kg (1540 LB).

30 mm thick access panel: greater than 900 kg (1980 LB)

Uniform ultimate load: 25 mm thick panel, greater than 12 kN / sq. meter.

30 mm thick panel, greater than 16 kN / sq. meter

Fire rating: meet BS: 476 Part 4, non-combustible.

Heat Transmission: very low. steel sheet at panel bottom, heat not transmitted by continuous steel to panel top.

Warranty: All components and materials shall be guaranteed to be free from defects for a period of 10 years from date of installation

In pursuing continuous quality improvement, the manufacturer reserves the right to vary the specifications without prior notice

patent granted – China: 200920006855.X / Taiwan: M365962

world patent pending: USA application number: P095465US,

SOLITILE[®]

--- a product division of Netfloor Inc ---

www.net-floor.biz



April 2011, Netfloor, Inc.